



■ Features

- Controls NAC devices
- NAC circuit rated up to 2A@30VDC max.
- SCI function
- Supports Class A and Class B wiring
- SEMS screws for easy wiring
- Status indicator LED
- Address settable from 001 to 254 by a dedicated programmer
- Low standby current (0.8mA)
- Mounts to optional 4-inch square electrical box

■ Description

EVA-SCM-SCI Sounder Control Module with Short Circuit Isolator is an output module intended for use in addressable two wire systems, which provides the control of NAC (Notification Appliance Circuit) devices. The module is used for Class A (Style Z) and Class B (Style Y) operation.

Indicator

This module has three colored LED to indicate the status of Output, Polling and SCI.



Output : Red LED
 Polling : Green LED
 SCI : Yellow LED

SCI Function

The module has a built-in short circuit isolator. SCI circuit prevents entire loop failure in the event of a short between L+ and L- on the loop.

Mounting

The module can be mounted directly to optional 4-inch square electrical box. The box must have a minimum depth of 2 1/8 inches.

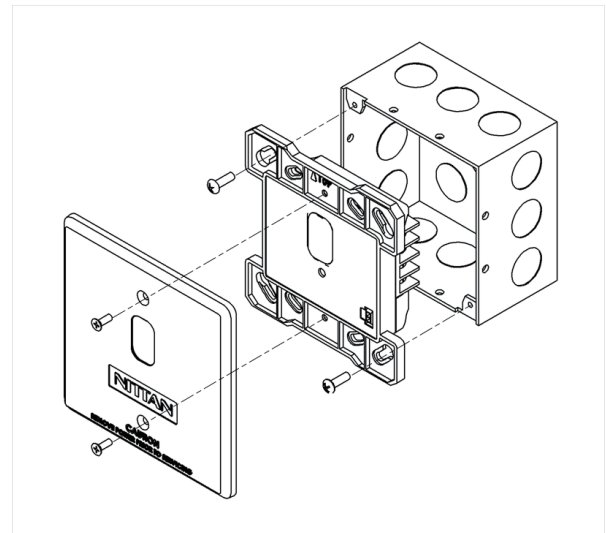

■ Wiring

Class A (Style Z)

Open-Circuit Detection/ Short-Circuit Detection

Connect Listed synchronization module EVCA-AP-SMD10 for the synchronization of NAC devices.

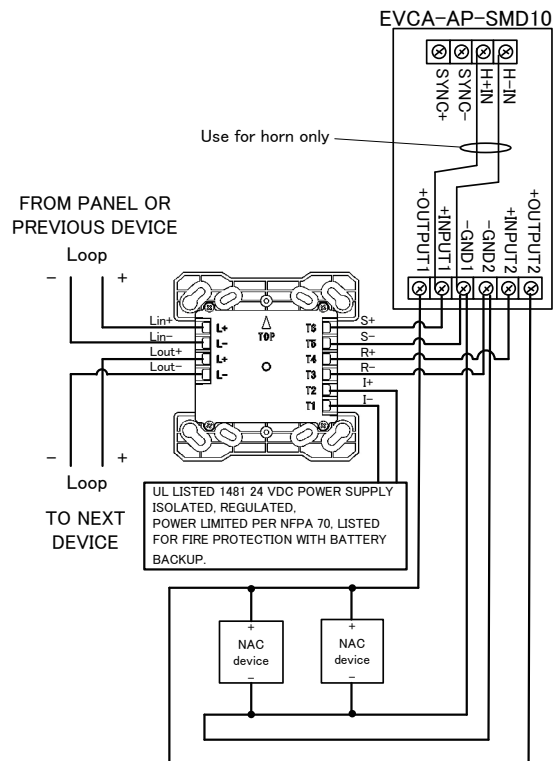

Setting	Value
Wiring Method	Class A (Style Z)
Open-Circuit Detection	Yes
Short-Circuit Detection	Yes

Class B (Style Y)

Open-Circuit Detection/ Short-Circuit Detection

EOL (10k ohm) is connected between S+ and S- in EVA-SCM-SCI. Refer to Figure 5 for wiring. Connect Listed synchronization module EVCA-AP-SMD10 for the synchronization of NAC devices.

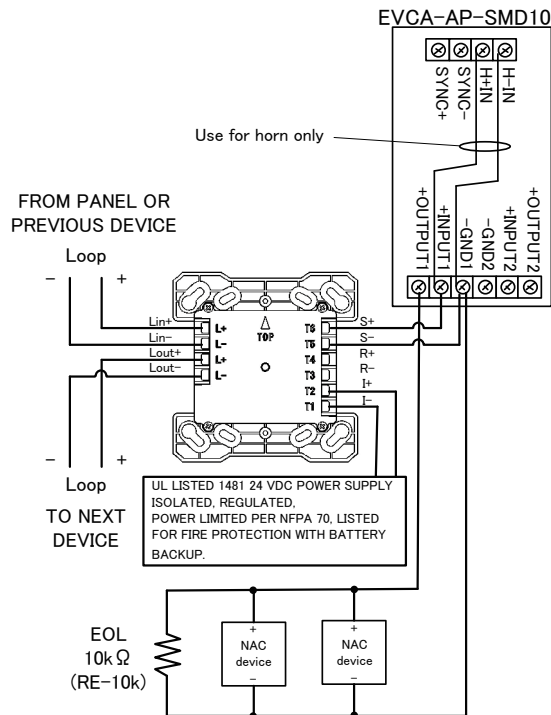

Setting	Value
Wiring Method	Class B (Style Y)
Open-Circuit Detection	Yes
Short-Circuit Detection	Yes

■ Connectable NAC Devices

Refer to the following table for listed NAC devices to be connected.

Detector Model	Manufacturer	Description
EVCA-AP-H	NITTAN	Horn
EVCA-AP-S	NITTAN	Strobe
EVCA-AP-SH	NITTAN	Horn & strobe
EVCA-AP-SWP	NITTAN	Weather Proof Horn
EVCA-AP-SHWP	NITTAN	Weather Proof Horn & strobe

Note: The number of NAC devices that can be connected varies depending on settings, but shall not exceed 14 devices.

Please refer to the specifications of NAC devices for the consumption current and DIP switch setting. Do not exceed the maximum current rating 2A and 14 maximum number of NAC devices.

Select the "temporal" tone in each NAC device for a standard evacuation pattern.

■ Specifications

Specifications	EVA-SCM-SCI
Applied Voltage	SLC Rated Range 20 to 38 VDC I± Rated Range 16 to 30 VDC
SLC Current Consumption	Standby 0.8 mA Alarm 3.6 mA
SLC Line Impedance	Up to 50 Ω
Relay (±I)	Switching capacity 30 VDC@2 A
Number of NAC Circuits	1 x Class A or 1 x Class B
NAC Circuit Rating	16 to 30 VDC, 2 A (max)
NAC Line Impedance	Up to 50 Ω
EOL Device	RE-10 k (10 kΩ, 1/4 W), Class B only
SCI on Resistance	0.2 Ω (max)
SCI Fault Detection Threshold	10 V (min)
SCI Isolation Current	22 mA (max)
Visual Indicator (Status LED)	Polling LED (GREEN) Output LED (RED) SCI LED (YELLOW)
Ambient Installation Temperature	0 °C to 49 °C (32 °F to 120 °F)
Storage Temperature	-20 °C to 60 °C (-4 °F to 140 °F)
Max Relative Humidity	Up to 93 % RH, non-condensing
Environment	Indoor dry use only
Max quantity per loop	127 units
Terminal	Screw AWG12 to 22
Address Setting	EVA-AD2 Address Programmer
Dimensions	H 124 mm x W 124 mm x D 34.5 mm (4.882" H x 4.882" W x 1.358" D) (Mount to a 4" square by 2 1/8" deep box)
Weight	Approximately 167 g
Conformity	UL864

Distributed By

All specifications are subject to change without any notice.
For more information, contact with NITTAN.

NITTAN

54-5, 1-chome, Sasazuka,
Shibuya-ku, Tokyo151-8535, Japan
TEL:81-3-5333-7021 FAX:81-3-5333-8615