

Before Installation

Please read these instructions carefully and keep for future reference.
The information in this document is subject to change without notice.
For updates please refer to our website.

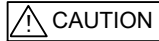

Do not use the products outside the rated power supply voltage range specified in the Specifications. It may cause a fire or damage to equipment.

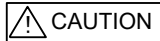

Do not disassemble, repair, or modify the products. It may cause a fire or electric shock.

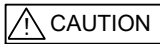

Make sure to turn the power off before commencing any wiring work. Otherwise it may cause electric shock or damage to equipment.

Note: Follow the requirements for the installation of the product in accordance with the Specifications. Otherwise it may cause damage to equipment.

Note: Do not install the product in any location where oil, dust, iron powder, chemicals, or hydrogen sulphide may occur or affect the product. It may cause damage to equipment.

This package contains the following items:

Main unit.....	1
Instruction Manual	1
EOL Resistor (RE-10k).....	1
Sealing label.....	1

General Description

EVA-MiniIP Mini Input Module is intended for use in addressable two wire systems. The module monitors and transmits the status (normal, open, short, or active) of devices equipped with NC/NO dry contacts to a control panel. The initiating device circuit (IDC) can be wired on Class B.

General Operation

Normal standby condition: The module receives polling from the control panel at the regular interval.

Active condition: When the external input is activated, the module communicates to the control panel the active status.

Trouble condition: The module communicates to the control panel the open/short status of IDC, depending on the Subtype Setting described below.

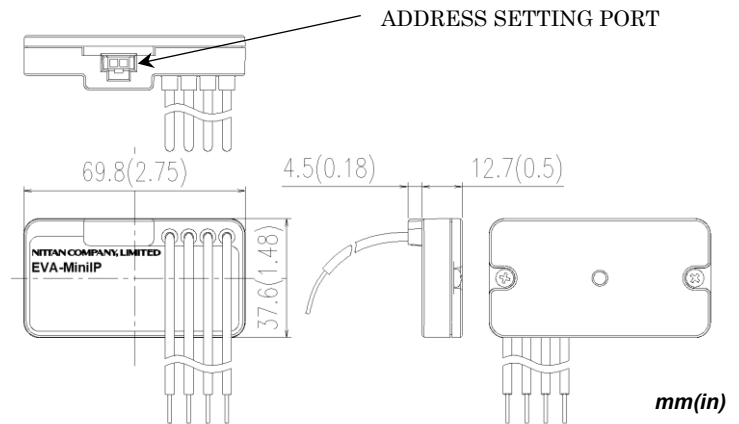

Figure 1

Compatibility Requirement

To ensure proper operation, the module shall be connected to UL listed control panel NFU-7000 series. Any conventional detector cannot be connected with the module.

Before Installing

Disconnect power to the control panel before installing the module. If the module is installed in an existing operational system, inform the operators and local authorities that the system will be temporarily out of service.

Mounting

Mount or place the module on the back or inside of monitored unit. Its small size and light weight allow it to be installed without rigid mounting.

Setting

• Address Setting

Use EVA-AD2 Programmer for setting the address of the module prior to installation. EVA-MiniIP has an address given at random from factory. Connect the Programmer with the address setting port to change the address to any of 1-254 (dec), with reference to the instruction manual of EVA-AD2 Programmer. The address can be set

regardless of whether power supply from the control panel is turned on or off. Refer to Figure 1.

Note: After setting the address, cover the address setting port by using the sealing label in order to prevent foreign material from entering the product.

During setting address, the module does not respond to the control panel.

Set the address of module according to Job data.

• **Subtype Setting**

Set the subtype depending on the wiring configuration as below. The subtype is to be set through the Configurator for the control panel.

Sub type	Input Method	Open -circuit Detection	Short -circuit Detection	Class	Interrupt
1	Normally Open	Yes	No	Class B	Disabled
2					Enabled
3	Normally Close	No	Yes	Class B	Disabled
4					Enabled
5	Normally Open	Yes	Yes	Class B	Disabled
6					Enabled

When interrupt is enabled, it allows a high priority communication to the control panel. The consumption current increases with this setting.

Note : Applicable subtype setting differs depending on control panels.

Subtype 1 to 6 can be used with the control panel complying with UL864 9th edition.

Subtype 5 and 6 can be used with the control panel complying with UL864 10th edition.

Please contact Nittan customer service for any required details.

Wiring

All wiring must conform to applicable local codes, ordinances, and regulations.

Install module wiring in accordance with the appropriate wiring diagrams.

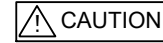

Do not connect cables in reverse polarity. Failure to connect the polarity correctly could result in damage to the module and/or other equipment.

Note : All wiring is power-limited and supervised.

Note : The SLC (signaling line circuit) of EVA-MiniIP supports Class A and Class B wiring, and does not support Class X.

Class B (Short circuit detection is not available)

EOL (10k ohm) is connected between A+ and A- in EVA-MiniIP.

Dry contact is OFF.

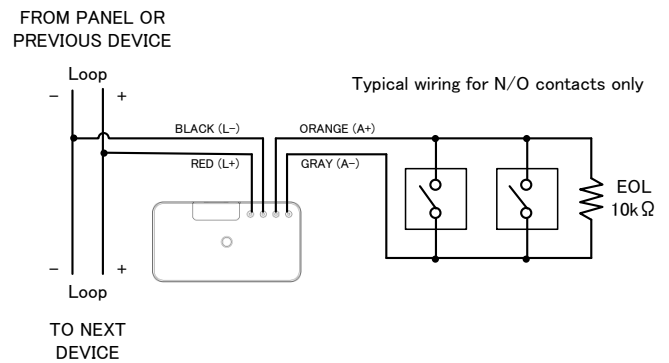

Figure 2

Class B (Short circuit detection is available)

EOL (10k ohm) is connected between A+ and A- in EVA-MiniIP.

Dry contact is OFF.

*Two external inputs can be connected to one input line.

*Resistor of 2.2k ohms (RE-2.2k) is an option and not included in this product.

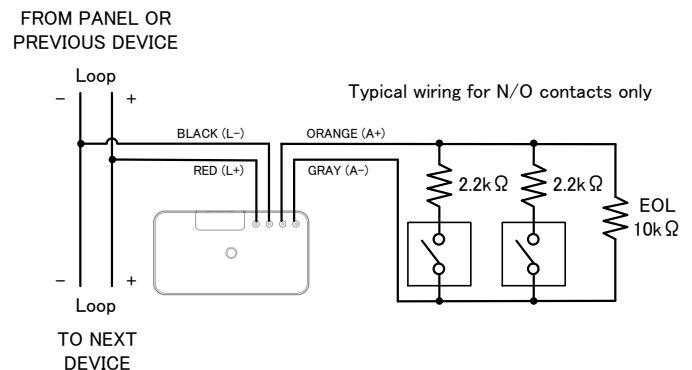

Figure 3

Normally Close Class B

Dry contact switch and EOL (10k ohm) are connected in series between A+ and A- in EVA-MiniIP.

Dry contact is ON.

*Only one external input can be connected to one input line.

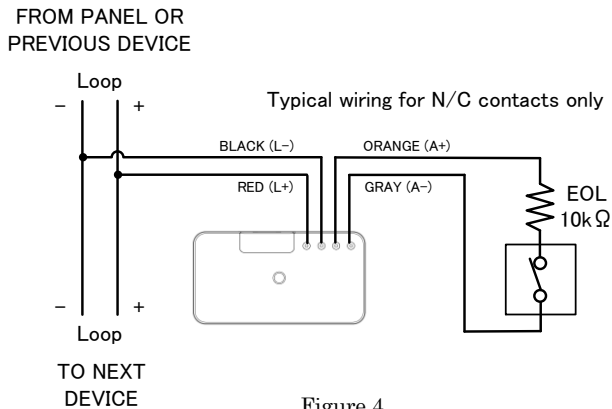

Figure 4

Maintenance

Routine inspection: Ensure the module is secure and undamaged.

Operation Test

The purpose of the Operational Test is to confirm the product's correct operation.

- 1) When carrying out site testing of the product, the control panel shall be set to "one-man-walk test mode" prior to the test.
- 2) Take any necessary precautions to limit the sounding of the alarm sounders/bells and any fire service summoning device.
- 3) Turn on the external input connected to the module, and the module will be in an active condition. Confirm that an active signal is transmitted to the control panel.

Note: If the test cannot be carried out through the external input, remove the wire connected to the external input, and test the area between A+ and A- to check the module. (In accordance with subtype setting, set the status either 0Ω short (for subtype 1-2), 2.2kΩ short (for subtype 5-6), or open (for subtype 3-4).)

- 4) After the external input has brought the module into the active condition, reset the external input. Confirm that the module goes back to the initial status after the external input is reset on the control panel.
- 5) If subtype is set as 1 and 2, or 5 and 6, open between terminal A+ and A-, and confirm that the control panel detects the open circuit. If subtype is set as 3-6, short between terminal A+ and A-, and confirm that the control panel detects the short circuit.

FOR WARRANTY SERVICE, RETURN TO:

OVERSEAS BUSINESS DIVISION, NITTAN COMPANY, LIMITED

1-54-5 SASAZUKA, SHIBUYA-KU, TOKYO 151-8535, JAPAN

<http://www.nittan.com>

Specifications

SLC (Signaling Line Circuit)	Rated Range 20 to 38VDC
Applied Voltage	
SLC Current Consumption	Standby 1.7mA Activated 7.2mA (max)
SLC Line Impedance	Up to 50 ohms
Number of IDC Circuit	1 x Class B
IDC Circuit Rating	15VDC, 2.2k ohms, 6.8mA(max)
IDC Line Impedance	Up to 50 ohms
EOL Device	RE-10k (10k ohms, 1/4W) 2.2k ohms EOL required for each dry contact switch in subtype setting 5 and 6
Ambient Installation Temperature	0°C to 49°C(32°F to 120°F)
Storage Temperature	-20°C to 60°C(-4°F to 140°F)
Max Relative Humidity	Up to 93% RH, non-condensing
Environment	Indoor dry use only
Maximum quantity per loop	127 units
Address Setting	EVA-AD2 Address Programmer
Dimensions	37.6mm H x 69.8mm W x 17.2mm D (1.480" H x 2.748" W x 0.677" D)
Weight	Approximately 34g (1.2oz)
Conformity	UL864

Warranties

1.1 Nittan warrants to the customers that:

- (a) all products supplied hereunder will be of merchantable quality and will comply with any specification agreed between Nittan and customer.
- (b) it is not aware of any rights of any third party in the market which would or might render the sale of the products, or the use of any of the trade marks on or in products, or the use of any of the trade marks on or in relation to the products, unlawful.

1.2 In the event of any breach of the Nittan's warranty in Clause 1.1(a) whether by reason of defective materials, production faults or otherwise, Nittan's liability shall be limited to:

- (a) replacement of the products in question; or
- (b) at the Nittan's option, repayment of the price where this had been paid. And the warranty period is three (3) years from the shipment from Nittan's factory.

1.3 Notwithstanding anything to the contrary in this warranty terms, Nittan shall not be liable to the customer by reason of any representation or implied warranty, condition or other term or any duty at common law, or under the express terms of this warranty terms, for any consequential loss or damage whether for loss of profit or otherwise and whether occasioned by the negligence of Nittan or its employees or agents or otherwise, arising out of or in connection with any act or omission of Nittan relating to Nittan or supply of the products, their use by any customer.

1.4 Customer shall indemnify Nittan against all loss, damages, liabilities, costs and expenses which Nittan may suffer or incur as a result of or in connection with any breach by customer of this warranties terms or any laws or regulations of any jurisdiction or any rules of any governing authorities.