

FLAME EYE™



■ Description

The DRD1-W is a triple waveband infrared flame detector ideal for indoor/outdoor non-hazardous environments. Its three built-in infrared sensors can detect fuel fires at long distances with a high immunity to false alarms.

The DRD1-W is equipped with a manual and automatic Self-Test function to assure continued reliable operation. Its Omniview™ indicator provides 360° visibility for easy status recognition by four types of color illumination.

The DRD1-W has the same interface to a previous model of 2RA3-PF, which provides compatibility for wiring.

Optional weather-proof hood offers an enhancement of tolerance to the rise of temperature due to the direct sunlight.



■ Features

- Triple waveband infrared flame detection for optimum false alarm immunity
- Detection range adjustable up to 60 m*
- Omniview™ 360°LED indicates the conditions of detector by four different color illumination (Alarm, Trouble, Startup, Testing)
- Self-Test function for monitoring window lens obscuration and circuit troubles
- Dust-Proof and Water-Proof
- Outdoor installation available
- Responds to flickering flames
- Selectable Response time and Self-Test cycle
- Stylish low profile design
- Current consumption approx. 6 mA (quiescent), 40 mA (max.)
- Equipped with an angle adjustable bracket having fine scale

* 0.1 m² n-Heptane pan fire

■ Dimensions

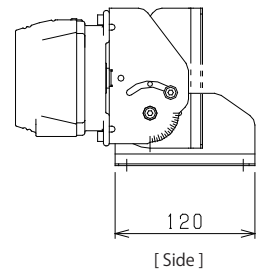
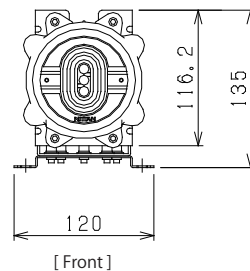
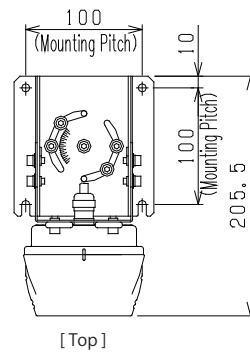

(mm)

NOT TO BE USED FOR INSTALLATION PURPOSES.

Nittan reserves the right to make changes at any time without notice in prices, colours, materials, components, equipment, specifications and models and also to discontinue models.

■ Directional Sensitivity and Range

Directional Sensitivity and Range

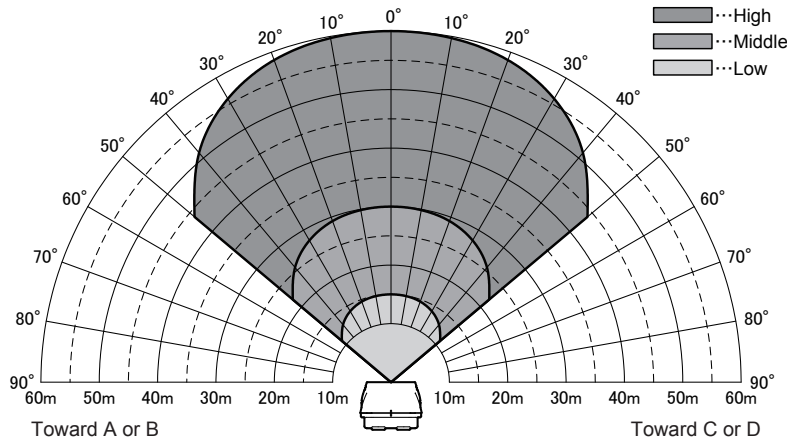

Direction

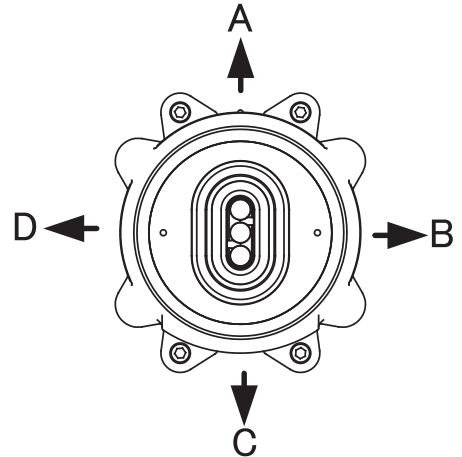

Selectable Detector Sensitivity

Detector Sensitivity	Detection Range
High (default)	60 m
Middle	30 m
Low	15 m

Detectable Flame Size

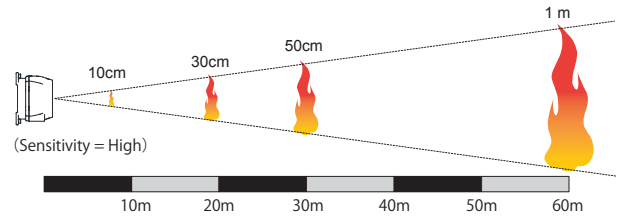

(N-Heptane fire on a 0.1 m² pan)

Detector sensitivity is selectable from 3 values by a dedicated setting tool. Detection range is a detectable distance for a 0.1 m² n-Heptane pan fire. The DRD1-W has a detection range of 60 m away and a wide angle of 100 degrees toward horizontal and vertical directions.

■ Triple Wavelength IR Detecting

Wavelength range for identifying a true fire

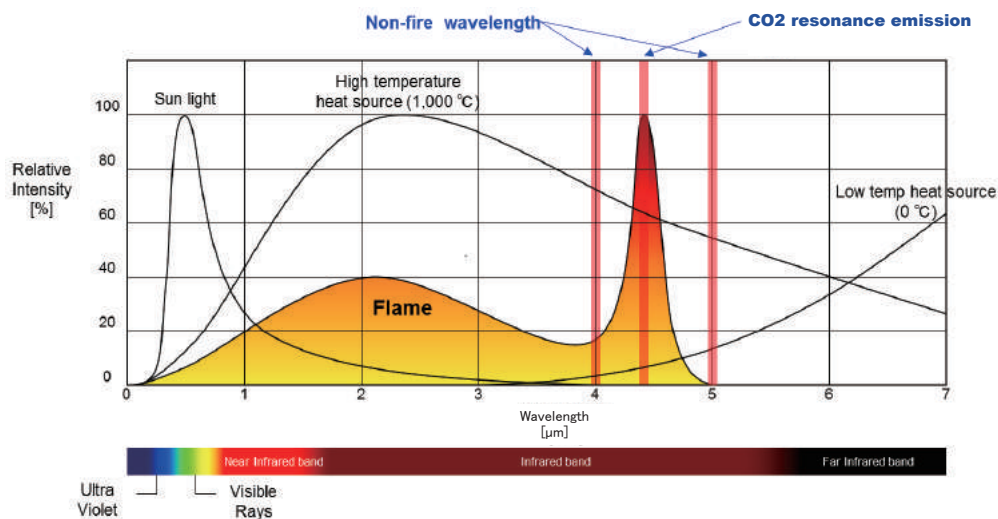

Fire (flame) has a characteristic peak at 4.4 μm in a spectral distribution, which is called as CO₂ emission. The DRD1-W has 3 sensors that monitor the band of CO₂ emission and two wavebands on either side respectively. The detector avoids false alarms by the feature of frequency-fluctuation detection.

■ OMNIVIEW™ 360° LED

The DRD1-W has a large ring OMNIVIEW™ 360° LED indicator to see detector status easily.

Red

Alarm



The previous model has two LEDs on the frame.

Yellow

Trouble



Green

Startup



Blue

Remote-Test



■ Self-Test Function

The DRD1-W has self-test function that checking lens condition or circuit status either automatically or manually to detect trouble condition. That is effective in preventing false alarms. The automatic self-test cycle is adjustable to either every 1 hr, 12 hrs or 1 week to meet with peripheral environment.



Lens (sensor)

Yellow light indicating when Lens or Circuit has trouble

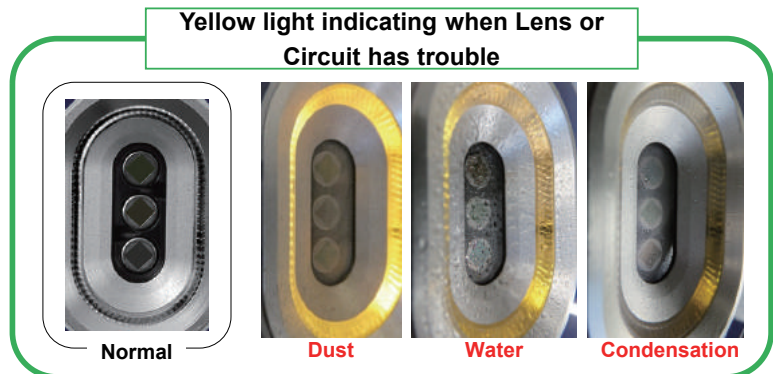

LED indication for each status

Test Function	Detector Status	Output Signal	LED Indicator
Manual Test (By remote test switch)	Normal	Fire	Red (steady)
	Lens Stains	Trouble	Yellow (steady)
	Circuit Trouble	Trouble	Yellow (steady)
Automatic Test	Normal	-	Off
	Lens Stains	Trouble	Yellow (steady)
	Circuit Trouble	Trouble	Yellow (steady)

Selectable Self-Test Cycle

Self-Test Cycle
Every 1 hr
Every 12 hrs
Every 1 week
Off

*Selectable by a dedicated setting tool. Default setting is 12 hrs.

Typical Wiring Dedicated Control Panel

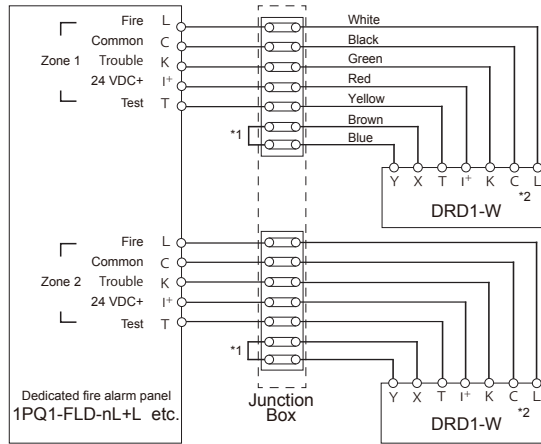

*1 Install a wire jumper between the terminals connected to Brown and Blue wires.

*2 The DRD1-W has a built-in End-of-Line device (CRE) in its enclosure.

Thus, the number of connectable detector is one per each zone.

Typical Conventional Control Panel

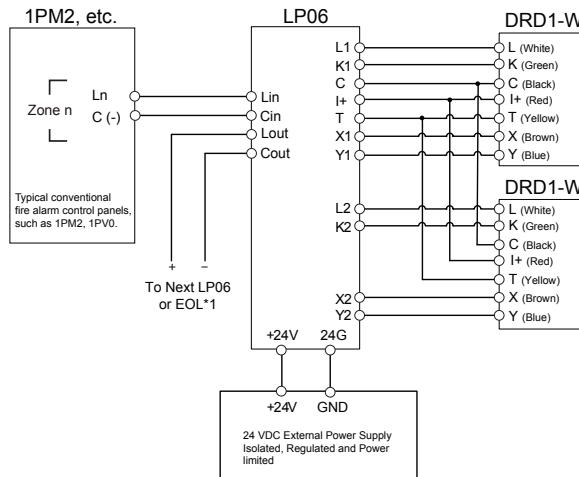

*1 A CRE End-of-Line Device must be installed at the last LP06 in the Ln and C circuit.

NFU-7000 Addressable Control Panel

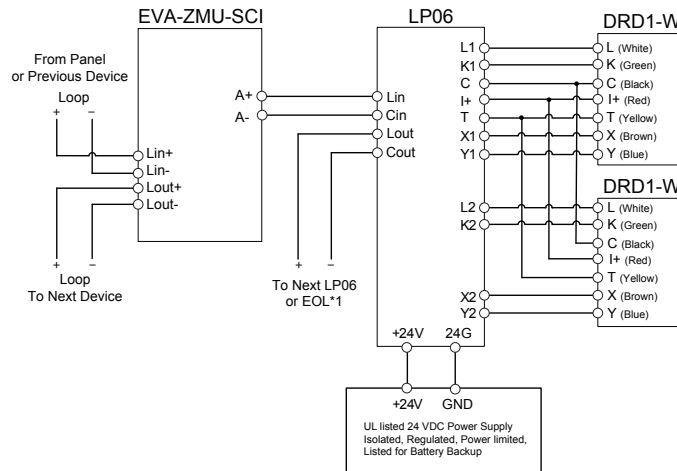

*1 A 10 kΩ End-of-Line Resistor must be installed at the last LP06 in the A+ and A- circuit.

■ Example of Applications

Applications	Solutions
Ironworks plant	Fire monitoring for the place where may become hot by motors
Printing factory	Fire monitoring for the large printing machine which uses organic solvent
Waste incineration plant	Monitoring for waste which may fire spontaneously in waste storage (Correspond to high-ceiling place)
Chemical factory	Monitoring for waste storage which may fire spontaneously

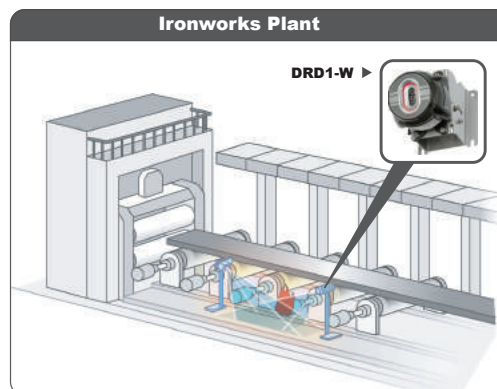

■ Specifications

Specifications	DRD1-W
Rated Voltage	24 VDC
Operating Voltage	19.2 VDC to 33.6 VDC
Rated Current	L - C : 50 mA K - C : 50 mA
Operating Current	I+ - C : 6 mA (quiescent), 40 mA (max.) L - C : 10 μ A and less K - C : 10 μ A and less
Sensitivity / Detection Range (for 0.1 m ² n-Heptane pan fire)	High : 60 m (default) Middle : 30 m Low : 15 m
Response Time	Instant : approx. 4 sec. Fast : approx. 8 sec. Normal : approx. 15 sec. (default) Prudent : approx. 30 sec.
Field of View	Horizontal 100°, Vertical 100°
LED Indicator	Alarm : Red (steady) Trouble : Yellow (steady) Remote Test : Blue (flashing) Startup : Green (flashing) Normal : Off
Automatic Self-Test Cycle	Adjustable to every 1 hr, 12 hrs (default), 1 week or OFF
Operating Temperature	-20°C to +60°C
Enclosure Rating	IP66 (Dust-proof, Water-proof) / IP67 (Dust-proof, Submersion-proof)
Dimensions	W 120 mm x H 145 mm x D 206 mm (with Mounting Bracket)
Weight	Approx. 1.5 kg (with Mounting Bracket)
Material	Body : Aluminum alloy (painted in dark bronze) Window : Sapphire Bracket : Stainless Steel
Connectable Fire Alarm Panel	Directly : 1PQ1-FLD-nL+L With LP-06 : 1PF, 1PK, 1PM, 1PN, 1PQ, 1PS, 1PV, etc. With ZMU and LP-06 : NFU-7000, NFU-7000-L
Optional Accessory	MTE2-RD: Flame Detector Testing Device DRD-14A: Weather-proof Hood

All specifications are subject to change without any notice.
For more information, contact with NITTAN.

NITTAN

54-5, 1-chome, Sasazuka,
Shibuya-ku, Tokyo 151-8535, Japan
TEL: 81-3-5333-7021 FAX: 81-3-5333-8615

Distributed By